

NOTE: 1
 DESIGN CODE:
 API 17H

NOTE: 2
 TECHNICAL CLASSIFICATION:
 Article Type: 008-Actuation
 Main Group: 8.03. ISO-6-7 Actuation
 Intermediate Group: 8.46.03. Gear
 Sub Group: 8.46.128.02. Intervention

NOTE: 3
 INTERFACE INFORMATION:
 Pressure Rating Bar: 300
 Design Water Depth: 3000m
 Material: N/A
 Weight: 71,1 kg
 Volume: 13,84 dm³
 Submerged Weight: 56,92 kg
 Surface Area: 30658 cm²
 Hydraulic: N/A
 Mechanical: ISO Class 4 Input
 Electrical: N/A
 Com. & Protocol: N/A

NOTE: 4
 ADDITIONAL INFORMATION:
 API 17H Class 4 to 7 gearbox for short term use / intervention.
 The gearbox is oil filled and pressure compensated using passive, integrated compensator. Main housing constructed in hard anodized Aluminum, nose section in POM and output socket in S165M.

Mechanical Gear box with ISO Class 4 input and ISO Class 7 output. 40kNm torque capacity.
 Gear Ratio 40kNm 1:14.273

Class 6 Insert available on request, BB1680

Can be configured to 10kNm and 15kNm torque output.
 Gear Ratio 15kNm 1:6 (ref BA6847)
 Gear Ratio 10kNm 1:3,78 (ref BA8497)

Gear Ratio 40kNm Long 1:14.273 (ref BB1677)

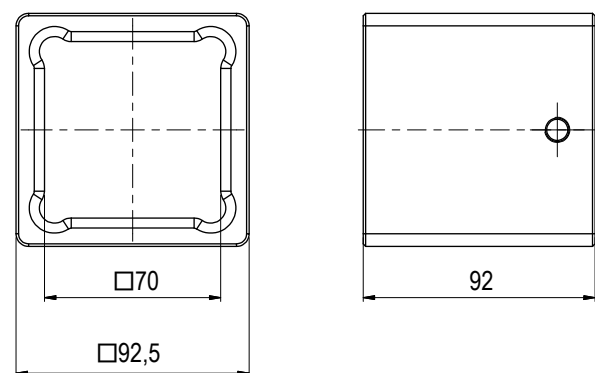
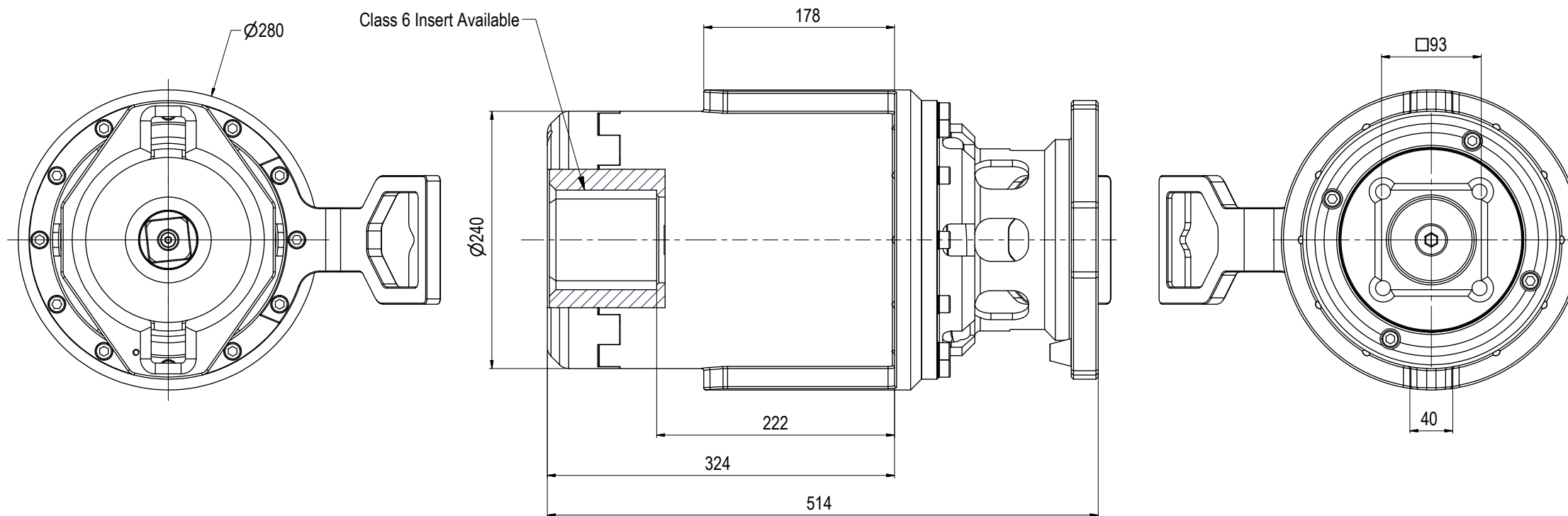

CLASS 6 INSERT BB1680

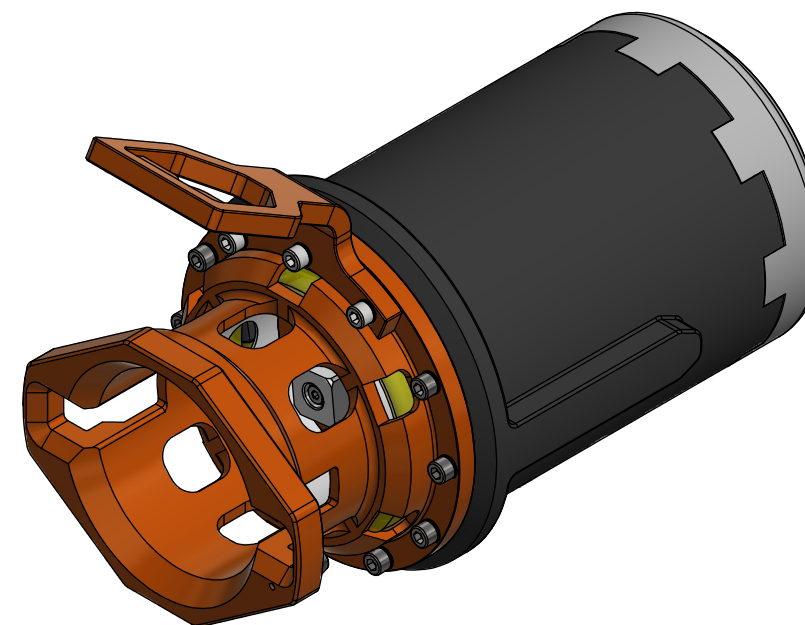

14	8.6.2026	9-IFU (Issued for Use)		WTJ	TAN	PBI
13	11.11.2024	9-IFU (Issued for Use)		WTJ	TAN	WTJ
12	20.9.2023	9-IFU (Issued for Use)		WTJ	LGH	WTJ
11	24.8.2022	9-IFU (Issued for Use)		WTJ	LGH	WTJ
Rev.	Date	Reason for issue	Revision change	Made	Chk'd	Appr.



This Drawing is the Property of Blue Logic AS © and must Not be Loaned, Reproduced or Transferred to others without written Permission

Dwg Scale:	NTS
Dwg Proj:	
Dwg Format:	A3

Drawing title:
 Class 7 Gear Box 40kNm

Drawing number:
 BA6403

Rev.
 14